

BITSENSOR 4 Axis CNC MACH 3 USB Controller

This 4 Axis CNC USB Controller is designed to be used for notebook and tablets, simple configuration and compatibility. The card can run what all other MACH 3 controllers can run and supports the drive shaft and the driven shaft, gantry supports automatic leveling, and has an output pulse 100 KHz.

Quick Spec

- Support for 4-axis linkage, you can connect four stepper motor drives or servo drives
- Maximum step-pulse frequency is 100KHz, which is suitable for the servo or stepping motor
- Support automatic probe tool
- Support Emergency input
- Support for limit switch
- Support for connecting electronic handwheel
- Need use external 24V DC power supply to isolate USB and external port, and to make the system more stable
- Have 0-10V output port, you can use mach3 software to control the spindle motor speed
- 4 general-purpose inputs, you can connect the limit switch, estop switch, probe switch, back to zero and other device
- 4 general-purpose isolated relay drive output interface, can drive four relays for controlling the spindle starts, forward rotating and reverse rotating, pumps and other device
- 1 status LED, indicate connection status on the board
- Size: 8x7.7cm/3.15x3.03inch

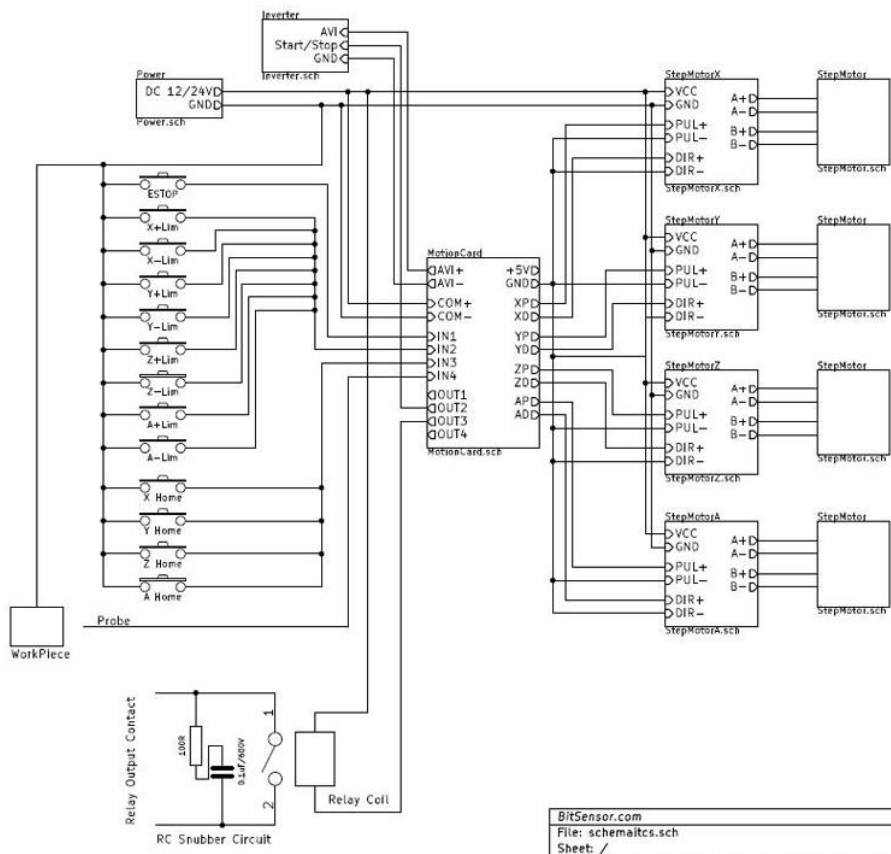

BitSensor.com	
File: schemaitcs.sch	
Sheet: /	
Title: BitSensor RnRMotion(ECO+) Controller Schematics	
Size: A4	Date: 28 oct 2014
KiCad E.D.A.	Rev: /
	Id: 1/12